

ITEM NO.	PART NO.	DESCRIPTION	QTY.
1	G014	seal, felt, T-REX	1
2	P518A	manifold, upper, vac, T-REX JR	1
3	G037A	o-ring, 11.75 Od x 1/8" width	1
4	B161	manifold, upper, solution, T-REX	1
5	G027	o-ring, 1.75" o.d. x 1/8" width	2
6	H090A	manifold, lower vac, TRex JR	1
7	G099A	brush, tile, TRex JR	4
8	H186	screw, 10-32 x 3/4, phil, flat, countersunk, s/s, black	16
9	B157A	manifold, lower solution, TRex JR	1
10	B176	plug, 1/8" npt, countersunk hex	1
11	B183	jet, 1/8", 1/8k 1.0, flood jet, brass	4
12	B217	check valve, 1/8" mpt x 1/8" fpt, 5 PSI	4
13	H036A	spray bar, 2.375", T-Rex	4
14	H248C	glide, TRex JR, s/s	4
15	H230	screw, 10-32 x 1/2" phil pan head, s/s	12
16	H018	screw, 10-32 x 1/2", FHSCS, s/s	20
17	H213	washer, 1/4" lock, s/s	4
18	H222	screw, 10-32 x 1-1/4" phil pan head, s/s	4

REVISIONS			
REV.	DESCRIPTION	DATE	APPROVED
OD	ORIGINAL DRAFT	12/24/2014	JFL
A	H036A REPLACES H036	9/15/2015	ML
B	ADDED H213, G099A, H186	11/7/2016	ML

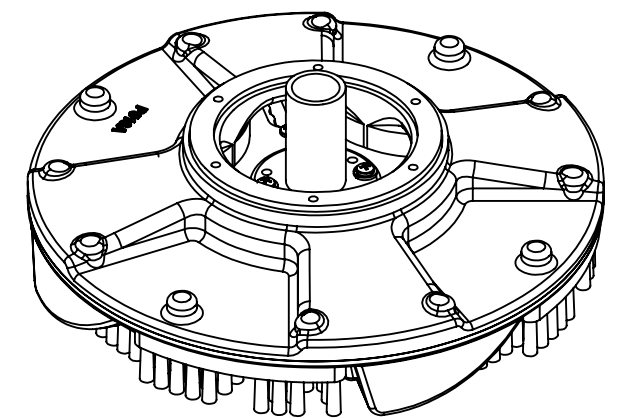
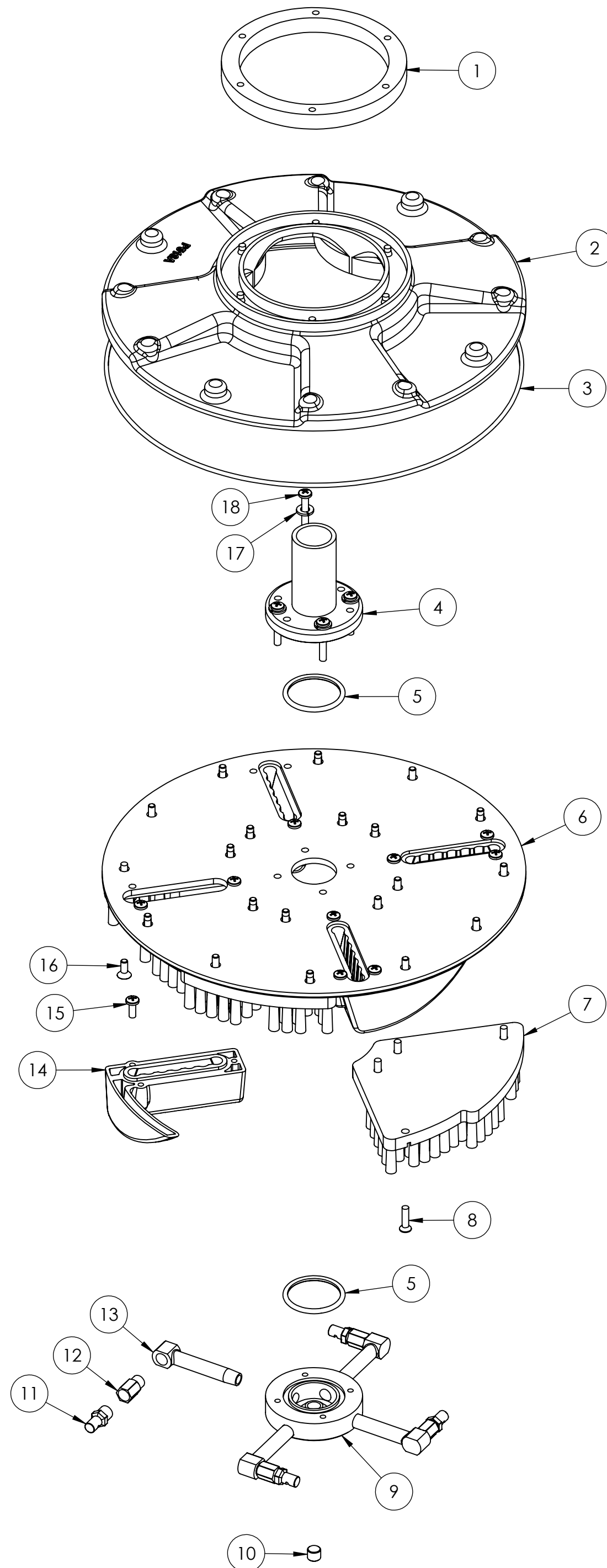

DRAWN	M.LaBarbera	DATE	12/2014	MYTEE PRODUCTS, INC. 858-679-1191	
CHECKED		TITLE:		assembly, cleaning head, TRex JR	
COMMENTS:				SIZE	DWG. NO.
<small> PROPRIETARY AND CONFIDENTIAL THE INFORMATION CONTAINED IN THIS DRAWING IS THE SOLE PROPERTY OF MYTEE PRODUCTS, INC. ANY REPRODUCTION IN PART OR AS A WHOLE WITHOUT THE WRITTEN PERMISSION OF MYTEE PRODUCTS, INC. IS PROHIBITED. </small>				C	A102A
				SCALE: 1:8	DO NOT SCALE DRAWING
				SHEET 1 OF 1	REV B